

2 7/8"  
(73 mm)

2 3/8"  
(60 mm)

# SIGHTGLASS ACCESSORIES

## Spray Washers

### TYPE II SPRAY WASHER

A convenient option for occasional or continuous automatic cleaning of the sightglass lens without the need to dismantle the lens. Permits clear, unobstructed viewing of vessel interior. Type II Spray Washer is available for NW100, NW125, NW150, and NW200. All parts in contact with the process fluid are made of stainless steel. Specify as TY II SW *Sightglass size*.

ITEM	DESCRIPTION
1	Connecting Pipe
2	Spray Head

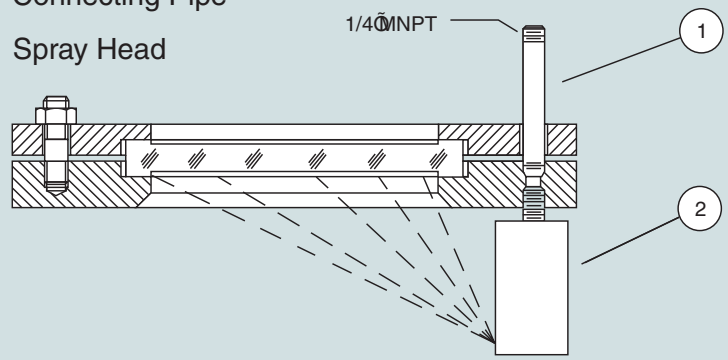

### TYPE III SPRAY RING

A convenient option for occasional or continuous cleaning of a sightglass lens without the need to dismantle the sightglass. The Type III Spray Ring can be used for our NW Weldpad Type Sightglass, NW-RF Flanged Type Sightglass, and FIF & FIS Series Sightflow Indicators. The Type III Spray Ring permits clear viewing of the vessel contents in applications where dirt, fog, or residue on the inside glass lens presents a problem. All parts in contact with the process fluid are stainless steel or virtually any machineable metal.



# SIGHTGLASSES