

2 7/8"
(73 mm)

2 3/8"
(60 mm)



MINI SIGHTLIGHTS SERIES MSL-HI-LED



SERIES MSL-HI-LED

The UL-1571 Listed Series MSL-HI-LED utilizes the most advanced high intensity LED technology available. The Series MSL-HI-LED "Light Engine" was developed specifically designed for the PAPAILIAS Co. to offer the same brilliant illumination as a 100 Watt Halogen Lamp and it is not a simple off the counter LED lamp. The MSL-HI-LED Series by PAPAILIAS Co. also features a heavy wall T304 SST housing and gasketed joints - making the MSL-HI-LED the brightest, longest lasting, heavy duty, corrosion resistant UL Listed light Fixture we ever offered. 110/120V input voltage [call for 24V & 220/240V]

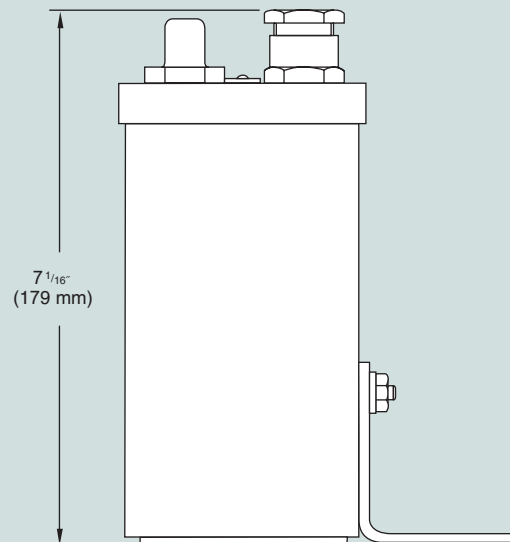
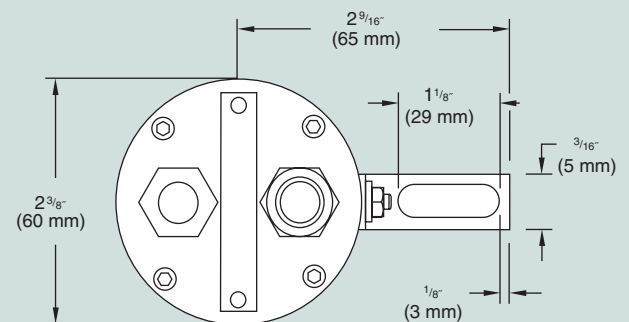

- NOT AN "OFF THE SHELF LED BULB" BUT A CUSTOM DESIGNED HI-LED LAMP FOR THE PAPAILIAS CO.
- EMITS AS MUCH OR MORE LIGHT INTENSITY [CANDLE POWER & LUMENS] AS A 100 WATT HALOGEN BULB. CONSUMES LESS POWER.
- BRIGHT WHITE LIGHT [HIGH COLOR TEMP.]
- DOES NOT GENERATE EXCESSIVE HEAT.
 - MAY BE LEFT ON CONTINUOUSLY
 - FIXTURE HOUSING DOES NOT GET HOT
- MORE ROBUST TECHNOLOGY – HI-LED LAMPS ARE NOT AFFECTED BY VIBRATION, IMPACT, HEAT, DUST OR SURFACE OILS.
- UL-1571 LISTED, NEMA 4X DESIGN FOR NON-HAZARDOUS LOCATIONS
- ALSO AVAILABLE FOR SELECT SIZES OF PAPAILIAS SERIES PL LIGHT FIXTURES.
- UL-844 LISTED EXPLOSION PROOF LIGHTING FIXTURES ARE ALSO AVAILABLE.

HIGH-INTENSITY LED LIGHTING