

2 7/8"
(73 mm)

2 3/8"
(60 mm)



4" MINI SIGHTLIGHTS Series MSL



SERIES MSL

The UL-1571 Listed Series MSL-100 mini sight light provides high intensity illumination for sightglasses and sight flow indicators. Manufactured in the USA from stainless steel and with gasketed joints, these fixtures are ideally suited for corrosive environments and sanitary applications found in the dairy, food, and pharmaceutical industries. Rated for 120 volts and 100 watts makes wiring simple and straightforward. Fixture is optionally available rated for 24 volts and 20, 50, or 100 watts.

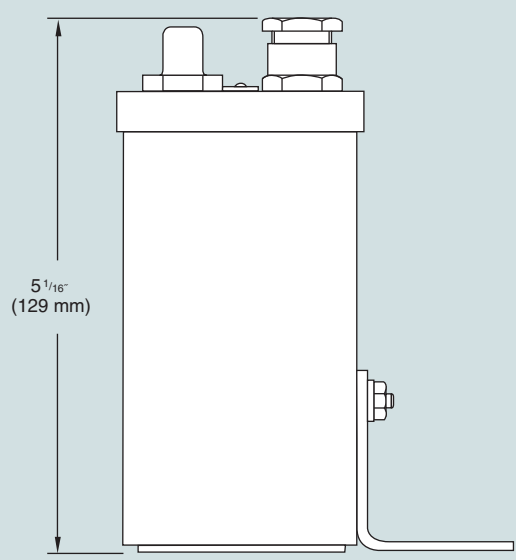
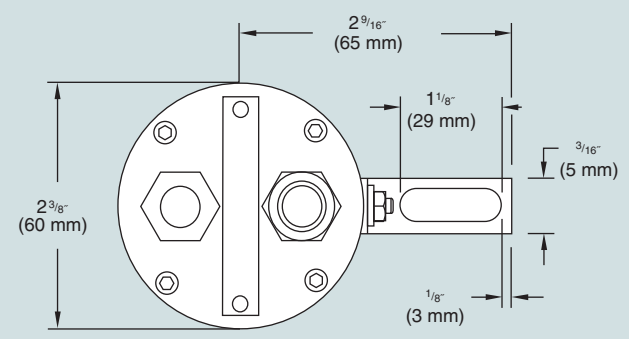

LIGHTING